

LED FIXTURE SPECIFICATIONS

CATALOG NO: MSL# M-TB-10-1
 OPTICAL SYSTEM: FLAT ARRAY W GLOBE
 IES CLASS: TYPE III
 INPUT WATTAGE: 40W
 SERIES: SOLID STATE LIGHTING
 CCT: 2700K
 LINE VOLTAGE: 120/277V
 PAINT: TEXTURED BLACK
 ELEC. CONNECTION: QUICK CONNECT
 WATTAGE SWITCH

POLYURETHANE FINIAL

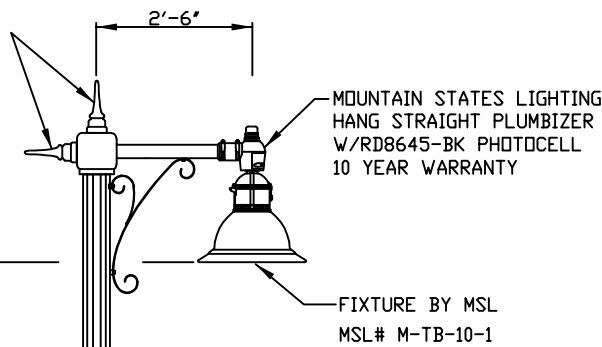

18'-0"

16'-7"

DECORATIVE BASE BY MOUNTAIN STATES LIGHTING
 # FRANK-17" X 40"-HDEB-BK
 HIGH DENSITY ELASTOMER BASE. PAINTED BLACK
 "CITY" LOGO IN GOLD
 BASE TO BE AN AVERAGE OF 5/8" THICK
 ALUMINUM OR STEEL NOT ACCEPTED

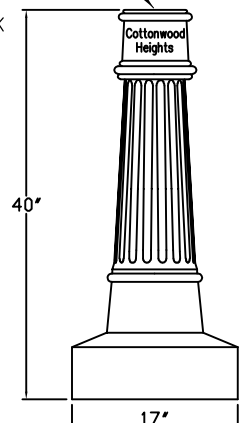

DECORATIVE BASE ENLARGED DETAIL

POLE BY MOUNTAIN STATES LIGHTING
 PART# 18EFA-5-TT/4x40D-FRANK-BK
 18' FLUTED ALUMINUM .25" WALL THICKNESS
 PAINTED BLACK WITH FIRST 16'
 OF POLE AND BASE PLATE TO BE
 COATED WITH INDUSTRIAL COLD GALV
 MIN EPA OF 20 IN 80 MPH ZONE
 (1.3 GUST FACTOR)

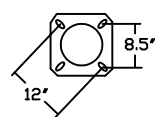
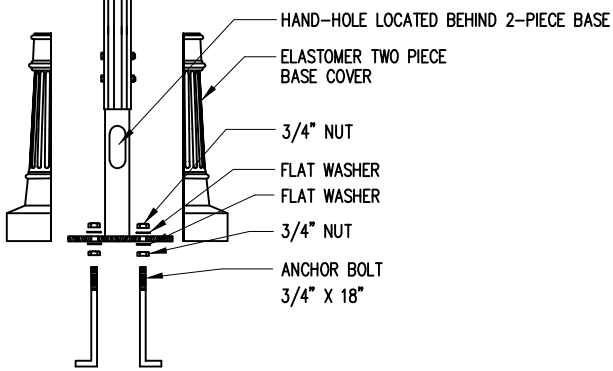

ANCHOR BASE DETAIL
 12" BOLT CIRCLE
 ANCHOR BOLTS: 3/4" x 18"

ASSEMBLY COLOR: BLACK



Cottonwood Heights
 2277 East Bengal Blvd.
 Cottonwood Heights, Utah 84121
 Phone 801-944-7000

Mountain States Lighting
 609 Krista Court
 Murray, Utah 84123
 Phone 801-268-4879
 Fax 801-605-9058

COTTONWOOD HEIGHTS RESIDENTIAL STANDARD

SCALE: NTS	DATE: 10/01/20	DRAWN BY: TM	DRAWING NUMBER: CH-SL-01
---------------	-------------------	-----------------	-----------------------------

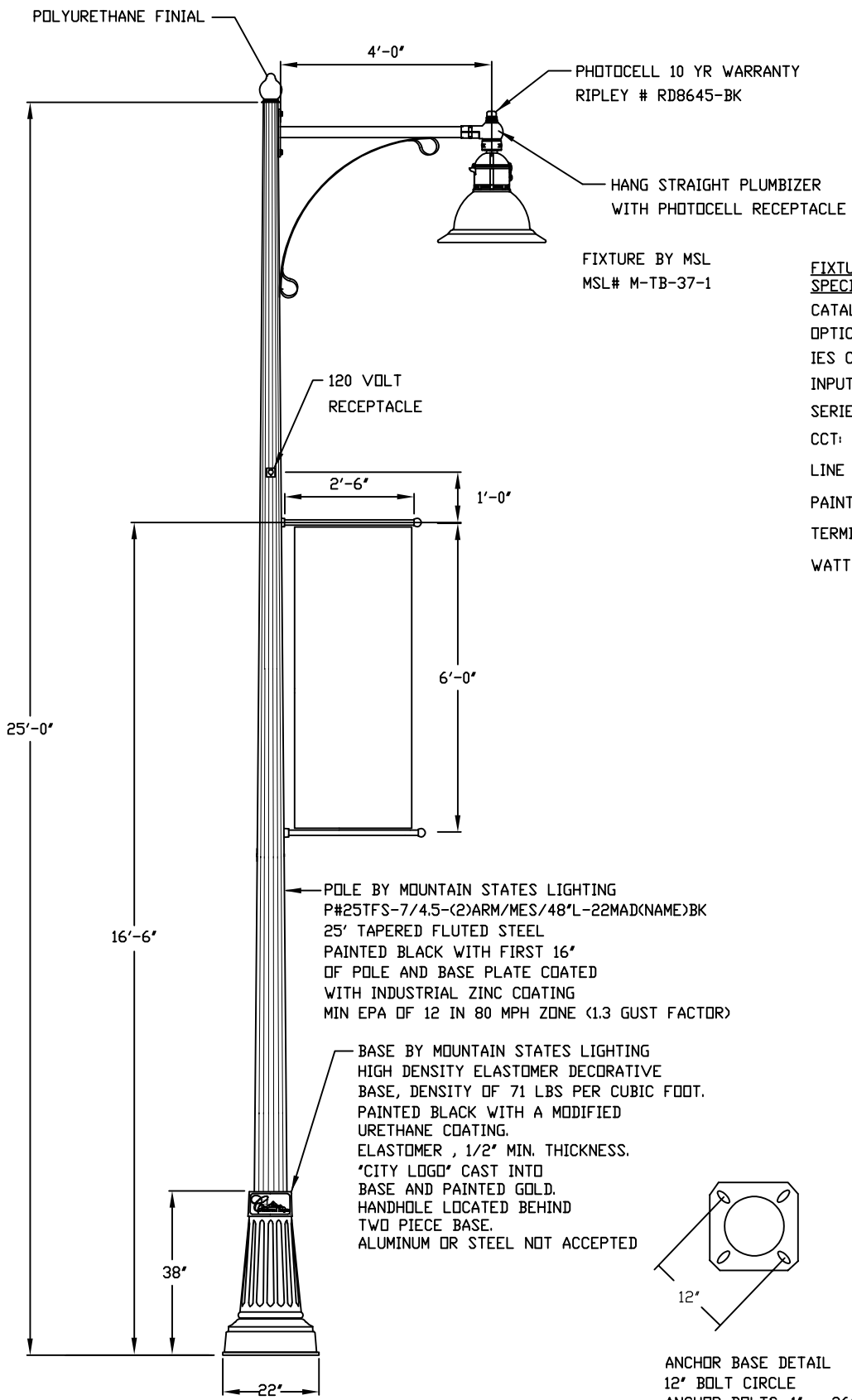
CITY APPROVAL:



FIXTURE SPECIFICATIONS
 CATALOG NO.: MSL# M-TB-37-1
 OPTICAL SYSTEM: FLAT ARRAY W GLOBE
 IES CLASS: TYPE III
 INPUT WATTAGE: 150W
 SERIES: SOLID STATE LIGHTING
 CCT: 3000K
 LINE VOLTAGE: 120/277V
 PAINT: TEXTURED BLACK
 TERMINAL BLOCK
 WATTAGE SWITCH

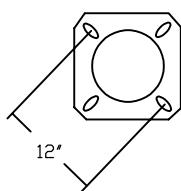

ANCHOR BASE DETAIL
12" BOLT CIRCLE
ANCHOR BOLTS: 1" x 36"

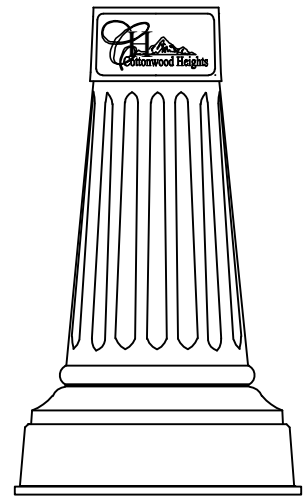

DECORATIVE BASE DETAIL

ASSEMBLY COLOR: BLACK

Cottonwood Heights
 2277 East Bengal Blvd.
 Cottonwood Heights, Utah 84121
 Phone 801-944-7000

Mountain States Lighting
 609 Krista Court
 Murray, Utah 84123
 Phone 801-268-4879
 Fax 801-605-9058

JOB NAME: **Cottonwood Heights
Arterial Single Teardrop Assembly**

SCALE: NTS	DATE: 10/01/20	DRAWN BY: TM	DRAWING NUMBER: CH-SL-02
----------------------	--------------------------	------------------------	------------------------------------

COTTONWOOD HEIGHTS CITY APPROVAL:

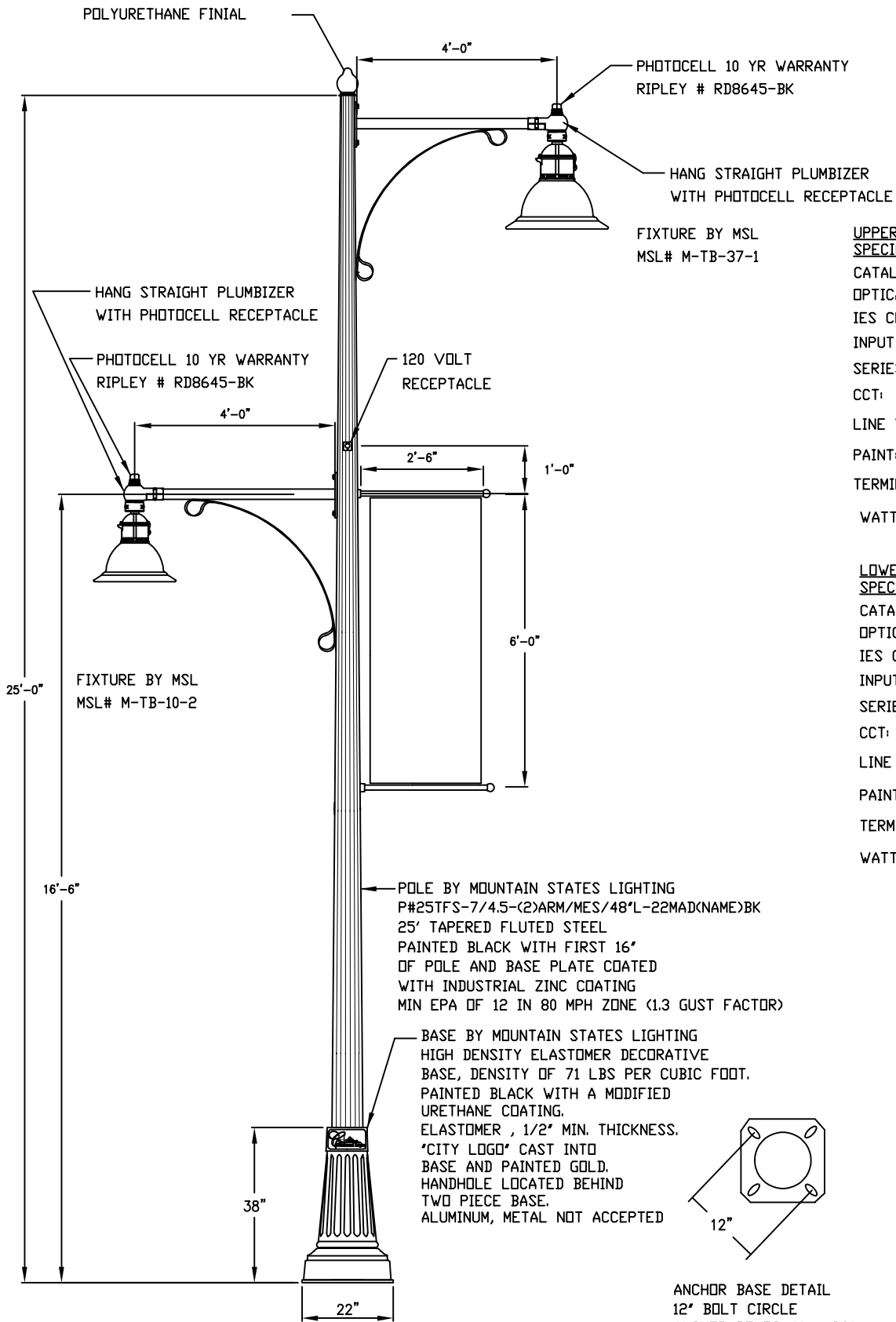

UPPER FIXTURE SPECIFICATIONS
 CATALOG NO: MSL# M-TB-37-1
 OPTICAL SYSTEM: FLAT ARRAY W GLOBE
 IES CLASS: TYPE III
 INPUT WATTAGE: 150W
 SERIES: SOLID STATE LIGHTING
 CCT: 3000K
 LINE VOLTAGE: 120:277V
 PAINT: TEXTURED BLACK
 TERMINAL BLOCK
 WATTAGE SWITCH

LOWER FIXTURE SPECIFICATIONS
 CATALOG NO: MSL# M-TB-10-2
 OPTICAL SYSTEM: FLAT ARRAY W GLOBE
 IES CLASS: TYPE III
 INPUT WATTAGE: 100W
 SERIES: SOLID STATE LIGHTING
 CCT: 3000K
 LINE VOLTAGE: 120:277V
 PAINT: TEXTURED BLACK
 TERMINAL BLOCK
 WATTAGE SWITCH

POLE BY MOUNTAIN STATES LIGHTING
 P#25TFS-7/4.5-(2)ARM/MES/48"L-22MAD(NAME)BK
 25' TAPERED FLUTED STEEL
 PAINTED BLACK WITH FIRST 16'
 OF POLE AND BASE PLATE COATED
 WITH INDUSTRIAL ZINC COATING
 MIN EPA OF 12 IN 80 MPH ZONE (1.3 GUST FACTOR)

BASE BY MOUNTAIN STATES LIGHTING
 HIGH DENSITY ELASTOMER DECORATIVE
 BASE, DENSITY OF 71 LBS PER CUBIC FOOT.
 PAINTED BLACK WITH A MODIFIED
 URETHANE COATING.
 ELASTOMER, 1/2" MIN. THICKNESS.
 "CITY LOGO" CAST INTO
 BASE AND PAINTED GOLD.
 HANDHOLE LOCATED BEHIND
 TWO PIECE BASE.
 ALUMINUM, METAL NOT ACCEPTED

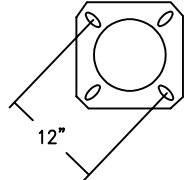

ANCHOR BASE DETAIL
 12" BOLT CIRCLE
 ANCHOR BOLTS: 1" x 36"

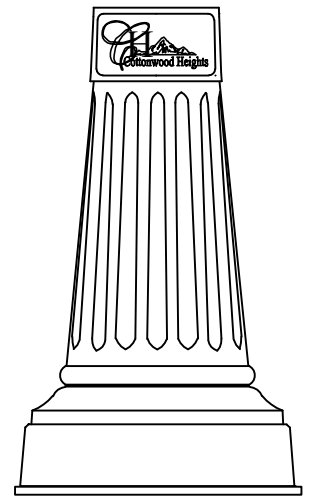

DECORATIVE BASE DETAIL
 ASSEMBLY COLOR: BLACK

Cottonwood Heights
 2277 E. Bengal Blvd.
 Cottonwood Heights, Utah 84121
 Phone 801-944-7000

Mountain States Lighting
 609 Krista Court
 Murray, Utah 84123
 Phone 801-268-4879
 Fax 801-605-9058

JOB NAME: Cottonwood Heights			
Arterial Twin Teardrop Assembly			
SCALE: <i>NTS</i>	DATE: <i>10/01/20</i>	DRAWN BY: <i>TM</i>	DRAWING NUMBER: <i>CH-SL-03</i>
COTTONWOOD HEIGHTS CITY APPROVAL:			

POLYURETHANE FINIAL

4'-0"

4'-0"

PHOTOCELL 10 YR WARRANTY
RIPLEY # RD8645-BK (TYP OF 2)

HANG STRAIGHT PLUMBIZER
WITH PHOTOCELL RECEPTACLE
(TYPICAL OF 2)

FIXTURE BY MSL
MSL# M-TB-25-1

FIXTURE BY MSL
MSL# M-TB-37-1

120 VOLT
RECEPTACLE

2'-6"

1'-0"

6'-0"

25'-0"

16'-6"

POLE BY MOUNTAIN STATES LIGHTING
P#25TFS-7/4.5-(2)ARM/MES/48"L-22MAD(NAME)BK
25' TAPERED FLUTED STEEL
PAINTED BLACK WITH FIRST 16"
OF POLE AND BASE PLATE COATED
WITH INDUSTRIAL ZINC COATING
MIN EPA OF 12 IN 80 MPH ZONE (1.3 GUST FACTOR)

BASE BY MOUNTAIN STATES LIGHTING
HIGH DENSITY ELASTOMER DECORATIVE
BASE, DENSITY OF 71 LBS PER CUBIC FOOT.
PAINTED BLACK WITH A MODIFIED
URETHANE COATING.
ELASTOMER, 1/2" MIN. THICKNESS.
"CITY LOGO" CAST INTO
BASE AND PAINTED GOLD.
HANDHOLE LOCATED BEHIND
TWO PIECE BASE.
ALUMINUM OR STEEL NOT ACCEPTED

38"

22"

FIXTURE
SPECIFICATIONS

CATALOG NO: MSL# M-TB-37-1
OPTICAL SYSTEM: FLAT ARRAY W GLOBE
IES CLASS: TYPE III
INPUT WATTAGE: 150W
SERIES: SOLID STATE LIGHTING
CCT: 3000K
LINE VOLTAGE: 120/277V
PAINT: TEXTURED BLACK
TERMINAL BLOCK
WATTAGE SWITCH

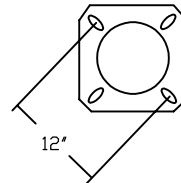

ANCHOR BASE DETAIL
12" BOLT CIRCLE
ANCHOR BOLTS: 1" x 36"

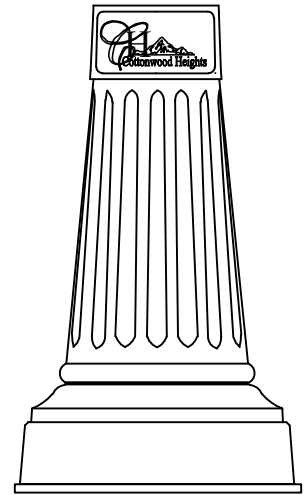

DECORATIVE BASE DETAIL

ASSEMBLY COLOR: BLACK



Cottonwood Heights
2277 East Bengal Blvd.
Cottonwood Heights, Utah 84121
Phone 801-944-7000



Mountain States Lighting
609 Krista Court
Murray, Utah 84123
Phone 801-268-4879
Fax 801-605-9058

JOB NAME: **Cottonwood Heights
Arterial Single Teardrop Assembly**

SCALE: NTS	DATE: 10/01/20	DRAWN BY: TM	DRAWING NUMBER: CH-SL-04
----------------------	--------------------------	------------------------	------------------------------------

COTTONWOOD HEIGHTS CITY APPROVAL: